

SS651-013, SS651MT-013 LCS653-013, and LCS653-1-013 Siren Amplifiers



Contents	<u>SS651</u>	<u>LCS653</u>	<u>LCS653-1</u>	<u>SS651MT</u>
Amplifier box	1	1	1	1
Wiring Connector	1	1	1	1
Control head (switch panel)	1	1	1	1
Blue ¼" quick connect terminals	0	6	3	0
Pink ¼" quick connect terminals	6	6	6	0

Input Voltage	10 - 16 VDC (negative ground)
Audio Input Current	8 Amps @ 13.6 VDC (100W speaker)
Standby Current	Enable wire off 0mA Backlighting off: 8 mA
Output Power	105 WATTS RMS MAX. (15.0 VDC - single 100W speaker)
Siren Frequency	675Hz - 5kHz
High Voltage Protection	> 16 VDC will cause siren output to cease, resume at normal < 10 VDC will cause siren output to cease, resume at normal
Short Circuit Current	50 AMPS (supply circuit must be capable of supplying this)
Operating Temperature	-15° F to +140°F
Size	Amplifier: 2" High, 6" Wide, 5-3/4" Deep (plus 3/4" flange on each side) SS651-CH / SSS651-CH4 Control Head (Switch Panel): 3" High x 3" Wide, x 1-1/2" Deep SS651-CH3 Control Head (Switch Panel) 3" High x 2-3/8" Wide, x 1-1/2" Deep SS651MT-CH - Weatherproof Control Head: 2.5" High x 4.5" Wide x 2-1/8" Deep (3" Deep with switches)
Boxed Weight	SS651, LCS653, and LCS653-1 - 3.4 lbs. SS651MT - 4.3 lbs.

Star Headlight & Lantern Co., Inc.
 455 Rochester Street Avon, NY 14414 Phone: 585-226-9787 FAX: 888-478-2797



www.starheadlight.com

TABLE OF CONTENTS

SPECIFICATIONS	Cover
INSTALLATION INFORMATION	1
GENERAL DESCRIPTION	1
INSTALLATION NOTES	2
MOUNTING	2-3
ELECTRICAL CONNECTIONS	4-6
WIRING DIAGRAMS	5-6
DIP SWITCH SETTINGS	7
OPTIONAL TONE PROGRAMMING	8
OPERATION	9
TROUBLESHOOTING	10
WARRANTY/SERVICE	11

Installation Information

MODELS: SS651-013 SS651MT-013 LCS653 LCS653-1	
SERIAL NO: _____	<i>DIP SWITCH OPTIONS</i>
PURCHASE DATE: _____	<input type="checkbox"/> Negative Aux. Polarity
DEALER: _____	<input type="checkbox"/> Hands Free Enabled
INSTALLATION DATE: _____	
INSTALLER: _____	
Model and serial number located on the bottom of the amplifier unit	

General Description

The SS651, SS651MT, LCS653, and LCS653-1 Sirens are designed for single 100W speaker use. They come standard with the amplifier unit as well as a remote control head (switch panel). The primary operating modes are Wail, Yelp, Standby, Manual, and Horn. Both the Manual Control and the Horn function will override all other functions, and can be utilized at any time via a rocker switch. The Phaser function can be optionally disabled (reprogrammed) for any necessary applications.

These units are designed to allow maximum versatility in mounting. The control head is remote from the siren amplifier box creating a compact user interface panel that can be easily mounted under the dashboard. The amplifier box can then be mounted remotely in the trunk, under the dashboard, under the seat, or wherever convenient. The SS651MT offers a waterproof switch assembly for motorcycle and marine applications.

The siren amplifier has been designed with several protection features to provide exceptional field service. Excessively high voltage detection will disable the siren output to protect both the amplifier and the speaker. Fused inputs provide safety against reverse polarity. Speaker protection shuts down the output if the speaker output becomes electrically shorted. CAUTION: These protection features will not guard against overloading the outputs.

Installation Notes

Proper installation of the unit is essential for years of safe, reliable operation. Please read all instructions **before** installing the unit. Failure to follow these instructions can cause serious damage to the unit or vehicle and may void warranties.

Qualifications

The installer must have a firm knowledge of basic electricity, vehicle electrical systems and emergency equipment.

Keep These Instructions

Keep these instructions in the vehicle or other safe place for future reference. Advise the vehicle operator of the location.

Unpacking

Inspect contents for shipping damage. If any damage is found, alert the carrier immediately.

Mounting

AMPLIFIER BOX

The amplifier box should be mounted through its flanges using four #8 screws (not included) or other suitable fastener.

- Using the amplifier as a template, mark the location of the four mounting holes to be drilled. Be sure to check for obstructions behind the mounting hole locations.
- Drill the four mounting holes and secure the amplifier box using appropriate hardware (not supplied).



CONTROL HEAD

The control head is designed to be mounted in an easily accessible location such as under the dash, in the overhead console, or in a center console. Choose a mounting location convenient to the operator and away from any air bag deployment areas. Be sure to choose a location that has at least two inches of depth to accommodate the control head and cables. Consider wire routing and access to connections when selecting location as well.



- Using the switch panel unit itself as a template, mark the location of the two mounting holes to be drilled. Be sure to check for obstructions behind the mounting hole locations.
- Drill the two mounting holes and install the control using two screws or other suitable fastener (not provided).

!!! CAUTION !!!

- Mount in a location with adequate ventilation to prevent overheating.
- Devices should be mounted only in locations listed in SAE standard J1849.
- Controls should be placed within convenient reach of the driver.
- Assure clearances before drilling in vehicle.
- Sound levels produced by attached speakers can cause permanent hearing loss.
- Never operate this unit without adequate hearing protection for you and others in the area. (OSHA 1910.95)

(Mounting CONT'D)

MOTORCYCLE/MARINE AMP INSTALLATIONS (SS651MT ONLY!)

This SS651-AMP can be used on a motorcycle or for marine applications by sealing the case with silicone sealant along the mating edges and around the wire connector. In order to reduce water entry, the amplifier should be oriented with the wire connector faced down. Only the waterproof switch assembly found in the SS651MT (SS651MT-CH) should be used for wet location operation.

CONTROL HEADS

The control head is designed to be mounted in an easily accessible location such as under the dash, in the overhead console, or in a center console.



Choose a mounting location convenient to the operator and away from any air bag deployment areas. Be sure to choose a location that has at least two inches of depth to accommodate the control head and cables. Consider wire routing and access to connections when selecting location as well.

- Using the switch panel unit itself as a template, mark the location of the two mounting holes to be drilled. Be sure to check for obstructions behind the mounting hole locations.
- Drill the two mounting holes and secure the switch panel using appropriate hardware (not supplied).
- Permanently mount the control using two screws (not provided).

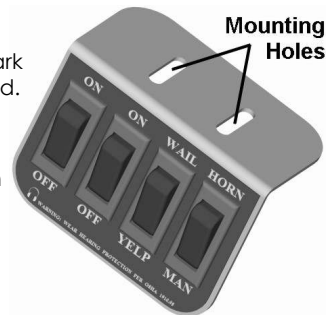

SS651MT-CH CONTROL HEADS

The SS651MT-CH weatherproof control head is designed for use in locations that may be exposed to water.

- Choose a mounting location convenient to the operator and away from any air bag deployment areas.
- Be sure to choose a location that has at least two inches of space on the right side to accommodate the cable exiting the side of the control head.
- Consider wire routing when selecting location as well.
- The SS651MT-CH can be mounted through the two holes in the rear cover. To gain access to the mounting holes, detach the rear cover by removing the four screws affixing it to the control head.
- Secure the switch panel using appropriate hardware (not supplied).

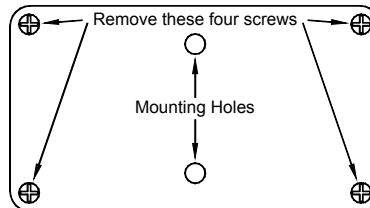

Rear of SS651MT-CH

Electrical Connections

Wire Size and Termination

Electrical connections to this unit are made through the green 10-terminal connector located in the rear of the unit (P/N P30041-177).

Examine the charts below to determine the proper gauge of the wire you should use. Please review the following recommendations to follow when making your installation:

- Use only high quality crimp connectors. Make sure all connections are tight.
- Minimize the number of splices to reduce voltage drop.
- Route wiring to prevent wear, overheating, and interference with air bag deployment.
- Use grommets and sealant when passing through compartment walls.
- Ground connections should only be made to substantial chassis components, preferably directly to the negative of the vehicle battery.
- Install and check all wiring before connection to vehicle battery.
- **CAUTION: All wires should be rated for at least 125% of their maximum current load. All wires connected to the positive terminal of the battery should be fused at the battery for their rated load.**
- Review the charts below that indicate the recommended wire gauge, based upon the length of the wire run and the current that will pass through the wire.
- Wiring packages are available from your distributor (Star P/N SWH-151).

RECOMMENDED WIRE GAUGE

Current	10'	20'	25'
< 2.0A	22 AWG	18 AWG	18 AWG
4.0A	18 AWG	16 AWG	16 AWG
5.5A	18 AWG	16 AWG	14 AWG
8.0A	16 AWG	14 AWG	14 AWG
12.0A	16 AWG	12 AWG	12 AWG



AMPLIFIER WIRING GUIDE

Input/Output	Description	Typical Color	Typical Current
A	Manual Switch	Blue	0.001 AMPS
B	Horn	Gray	0.001 AMPS
C	Yelp	Violet	0.001 AMPS
D	Wail	White	0.001 AMPS
1	AUX	Green	0.002 AMPS
2	Ignition Switched Power	Yellow	0.14 AMPS
3	Speaker 1	Brown	4 AMPS
4	Speaker 2	Brown	4 AMPS
5	Battery Negative/Ground	Black	11 AMPS
6	Audio/Siren Power	Red	10 AMPS

(Electrical Connections CONT'D)

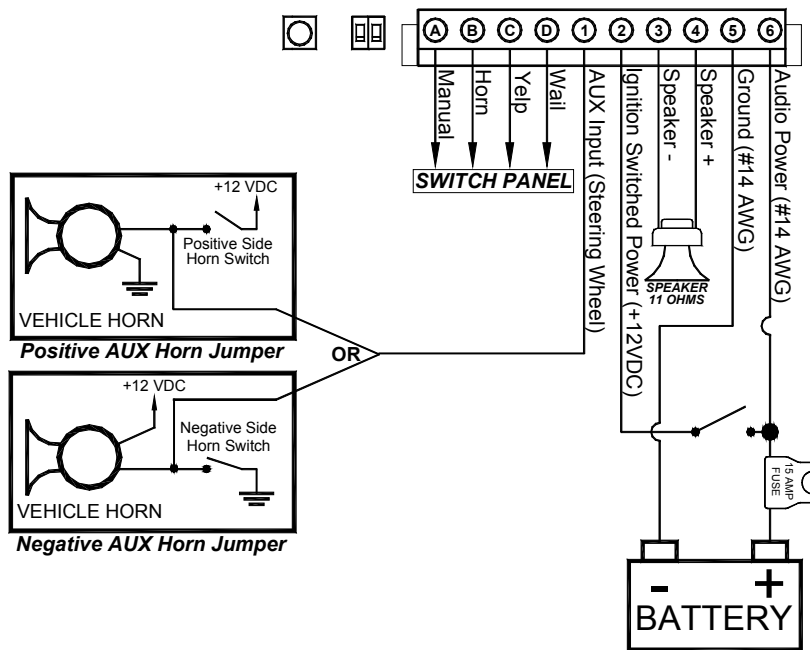
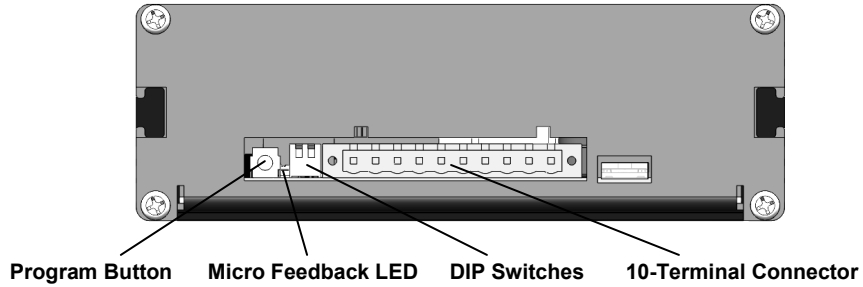

MANDATORY ELECTRICAL CONNECTIONS

Ground - Connect terminal 5 to the negative terminal of the battery.

⚠ (You MUST connect this wire!!)

Enable - Connect terminal 2 to a 10-16VDC ignition switched power source.

⚠ (You MUST connect this wire!!)

Audio Power - Connect terminal 6 to 10-16VDC through a 15A fuse.

⚠ (You MUST connect this wire!!)

Speaker - Connect terminals 3 and 4 to your speaker.

OPTIONAL ELECTRICAL CONNECTIONS

AUX Input - If you will be using the Hands Free option (see page 7) to activate and change siren tones with the vehicle horn, connect terminal 1 to the horn switch. Be sure that you have set DIP switch #1 for the correct polarity (see page 7).

(Electrical Connections CONT'D)

CONNECTION OF CONTROL HEADS

SS651-CH (for SS651), SS651-CH3 (for LCS653-1), and SS651-CH4 (for LCS653)

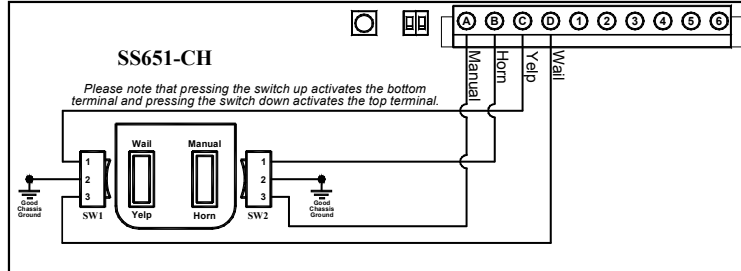

- Electrical power connections to the control head are made using the 1/4" quick connect terminals provided.
- After your wires are run from the location of the siren amp to the location of the control head, crimp the enclosed terminals on to the ends of the wires and plug them into the appropriate terminals on the back of the control head.

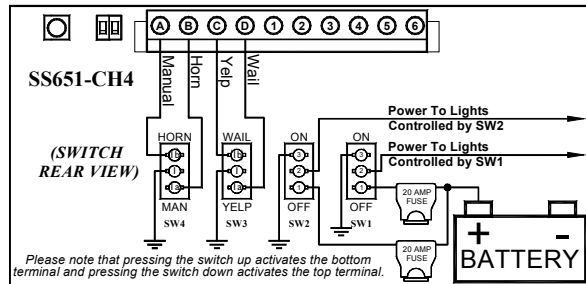
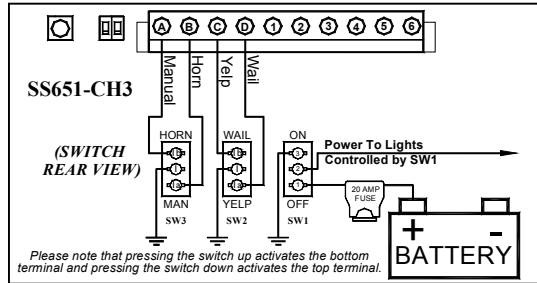

SS651MT-CH

The SS651MT-CH control head comes with 8' leads. They will be connected to the appropriate wires from the SWH-36 or lights by soldering or using appropriate connectors (user supplied) and/or additional wire when necessary. Refer to the diagram below.

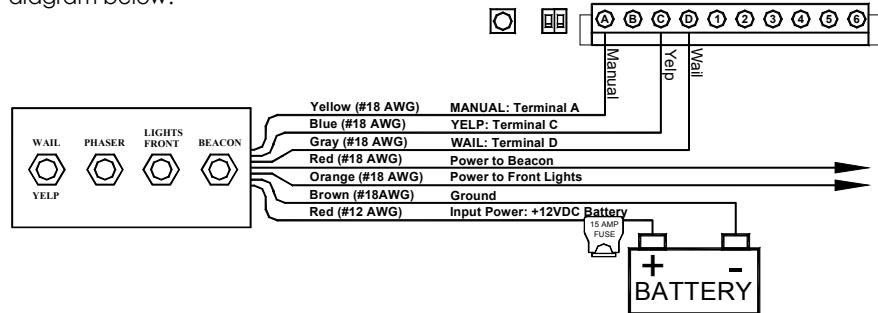

DIP Switch Settings

These sirens have two optional settings that can be selected during installation using the DIP switches located on the back of the amplifier case:

- Auxiliary Input Polarity
- Hands Free Cyclor Mode Enable

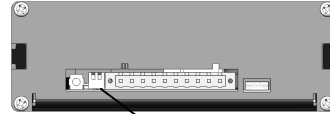

DIP Switches

DIP SWITCH	FUNCTION	UP (Off) <i>(default)</i>	DOWN (On)
1	AUX terminal Polarity	Positive switching	Negative switching
2	Hands Free Cyclor mode	Hands Free Cyclor mode disabled	Hands Free Cyclor mode enabled

DIP Switch 1 - Auxiliary Input Polarity (AUX Function)

Applying a positive voltage to the AUX input (Terminal 1 of the green connector) normally activates the auxiliary function (Air Horn standard, or Hands Free Cyclor function optional). To have the AUX function instead activate when Terminal 1 is connected to ground (negative), flip DIP switch #1 into the DOWN (On) position (as pictured to the right).

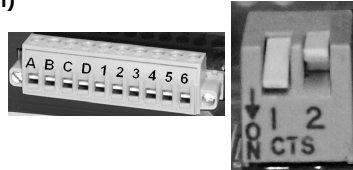

DIP Switch 2 - Hands Free Cyclor Mode Enable

This siren is shipped with the Hands Free Cyclor mode DISABLED. To enable Hands Free Cyclor mode, set DIP switch #2 into the DOWN (On) position (as shown to the right).

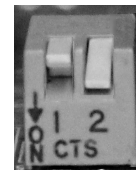

See page 9 for additional details on Hands Free Cyclor mode.



Optional Tone Programming

These sirens can be programmed to produce 6 different tones/sounds by activating its various functions:

<u>Function</u>	<u>Default Tone</u>
Wail	Wail
Yelp	Yelp
Yelp Step Up	Phaser
Manual	Ramp Up
Horn	Air Horn
Auxiliary	Air Horn



Each **Function** listed above can be programmed for a different tone. If you would like to change the tone for any of the six functions, follow the instructions below.

- Power the unit** up.
- Activate the function you wish to change.
 - For Wail and Yelp functions, flip the **Wail/Yelp** switch into the corresponding position.
 - For the Manual, Horn, or AUX functions, press **and hold** the **Manual** button, **Horn** button, or **steering wheel horn**, respectively.
 - For the Yelp Step Up function, flip the **Wail/Yelp** switch into the **Yelp** position, then press and release the **Manual** button.

The tone that is currently programmed for that function will sound.

- Press and release the **Program** button on the rear of the siren to cycle through the list of optional tones. *Review the chart below for a list of optional tones.*

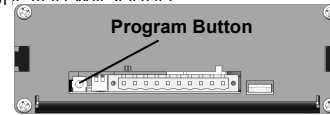

Tones For Wail, Yelp, and Yelp Step-Up Function	Tones For Manual Button and AUX terminal	Tones for Horn Button
1 WAIL (<i>Wail default</i>) §, *, †	1 STANDARD AIR HORN (<i>AUX default</i>)	1 STANDARD AIR HORN (<i>default</i>)
2 YELP (<i>Yelp default</i>) §, *	2 LOW FREQUENCY AIR HORN	2 LOW FREQUENCY AIR HORN
3 PHASER (<i>Yelp Step Up default</i>)	3 RAPID AIR HORN	3 RAPID AIR HORN
4 TWO TONE	4 AIR HORN II	4 AIR HORN II
5 MECHANICAL WAIL (FIRE ENGINE) †	5 DOUBLE POST POP AIR HORN	5 DOUBLE POST POP AIR HORN
6 MAX YELP §, *	6 SINGLE AIR HORN	6 SINGLE AIR HORN
7 HOOT	7 SINGLE QUICK AIR HORN	7 SINGLE QUICK AIR HORN
8 RAPID HOOT	8 TWO TONE AIR HORN	8 TWO TONE AIR HORN
9 AIR HORN & YELP	9 MANUAL (<i>MN default</i>) *, †	
10 GHOST	10 MECHANICAL MANUAL (FIRE ENGINE) †	
11 RAPID GHOST		
12 SINGLE AIR HORN		
13 SINGLE QUICK		
14 DOUBLE POST POP AIR HORN		
15 TWO TONE AIR HORN		
16 STANDARD AIR HORN		

§ = SAE approved
 * = California Title 13 approved
 † = See below

▶▶▶▶ System Reset ◀◀◀◀

If you would like to reset all of the siren programming options to their defaults, activate any tone and press the **Program button** for six (6) seconds. The LED will flash once, then twice, then all siren tones will stop.

Wind Down or Hard Stop Option

By default, the Wail and Manual tones indicated by the "†" above will "wind down" when they are de-activated. If you prefer to have them immediately stop (i.e. hard stop), hold the Program Button for 3 seconds (until the LED flashes once). This will change them to a hard stop. Repeat to change back to the wind down option.

Operation

Wail/Off/Yelp Button

This is the 3-position button used for basic operation of the siren. While in the Wail or Yelp positions the siren will produce the tone programmed for that function (see *previous page*). The Wail and Yelp functions are defaulted for the Wail and Yelp tones.

Wail Tone: A normal rise-fall tone used on highways and areas with low traffic or constant traffic flow.

Yelp Tone: A rapid warble tone used in light to moderately congested areas.

Center Off Position: (Manual/Standby) - A silent mode that allows momentary push-button activation of the Manual and Horn functions.



SS651-CH



SS651MT-CH



SS651-CH3



SS651-CH4

Manual Button

When the unit is powered up with the Wail/Off/Yelp button in the Off position (not producing any siren tones), by default this momentary push button switch provides a manually rising and falling siren tone while being pressed. The siren output winds down when the Manual momentary switch is released.

With the Wail or Yelp mode selected, pressing the Manual button will "step" the siren up to the next button's programmed tone:

(Wail → Yelp → Yelp Step Up)

These quicker tones are used to momentarily alert motorists at intersections and very highly congested areas. Pressing the button once changes to the next faster tone. Pressing the Manual button again, reverts the siren back to the original tone. (See *previous page to program optional tones.*)

Horn Button (SS651MT excluded)

This momentary push button switch provides a simulated air-horn tone while pressed. It is useful at intersections or in high noise areas. This tone will override all other siren tones. (See *previous page to program optional tones.*)

Auxiliary Function (AUX Terminal) and Hands Free Cyclers Mode

Note: Requires connection of the AUX terminal (see page 5).

The AUX terminal is typically connected to the vehicle horn switch. See page 7 to select positive (+12VDC) or negative (ground) activation.

Normally when the unit is on and in any mode, activating the AUX terminal (i.e. pressing the vehicle's horn) will produce the programmed Air Horn tone (see *previous page to program optional Air Horn tones.*)

If you enable *Hands Free Cycler mode* using DIP switch #2 as shown on page 7, pressing the vehicle's horn continuously for 3 seconds will activate the **Hands Free Cycler** mode. This mode allows you to use the vehicle's horn to cycle through the siren tones associated with the following functions:

(Wail → Yelp → Yelp Step Up → Silent)

Troubleshooting

Auto Shutdown

This unit is designed to automatically shut down when certain undesirable conditions exist, to prevent internal damage. All audio functions are disabled until the issue is corrected.

- Over Voltage/Under Voltage
- Over Current

Micro Feedback LED

This unit is designed with an LED that not only provides feedback when programming, but also helps troubleshoot audio issues.

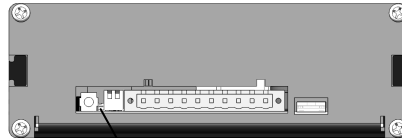

Micro Feedback LED

LED Pattern

Steady On
Off
Single Flash
Double Flash

Diagnosis

Speaker functioning properly
No Siren Tone Active or Speaker open (faulty connection)
Over Voltage/Under Voltage
Over Current

Symptom	Possible Cause	Check
No power	Check power Wires Fuse or circuit breaker blown	When activated, power to both Terminals 2 and 6? Is power hooked up backwards? Positive ground vehicle? Are the negative leads connected to a good ground? Measure voltage between ground & +12v terminal Measure voltage between ground & ignition switched terminal. Check Fuse under amplifier cover. Check external fuses or circuit breakers
No siren tone	Bad speaker or speaker wiring High voltage or low voltage protection Blown Fuse	Does LED remain off when siren tone is selected? Disconnect the speaker at the amplifier, and turn a tone on. If you hear sound, the siren is working correctly and you have a failed speaker or faulty speaker wiring . Is LED single flashing? Measure voltage between ground & ignition switched terminal. The input voltage must be between 10 & 16V Check fuse inside amp housing
Distorted siren sound	Speaker assembly loose Intermittent AUX input connection Low or high vehicle voltage	Is the speaker loose? Is the Aux. Input used and wired properly? Is LED single flashing? Input voltage must be between 10 & 16 volts while siren is on.
Intermittent siren tone	Low voltage protection Circuit breaker in supply connection Shorted speaker or speaker wire	Wires connected tightly to the back of the unit? Loose connection on a power lead? Input greater than 10V with the siren turned on? Is a circuit breaker used with at least a 30A rating? Does the speaker have water damage, or is a wire pinched?
Horn function or Manual function stuck on	Aux. Input improperly connected or Aux. Input Polarity Option set wrong	Remove the Aux input wire at the amp. Does the problem stop? If so the aux polarity DIP switch may be set wrong or the AUX terminal may be wired incorrectly
Wrong siren tone	Option accidentally changed	See programming and setting to defaults section

Service

PARTS

Part	Description
P30235-18-1P	Amplifier Top Cover
S30234-18-1	Amplifier Bottom Mounting Plate
SWH-151	Optional Wiring Harness (<i>not included</i>)
P30050-28	Rear Amplifier Case Screws
P30028-27	15 Amp Mini Automotive Blade Fuse for Amplifier
30032-8	TIP36C Power Transistor
30007-41	3-Position Rocker Selector Switch (WAIL/YELP)
30007-42	Momentary Rocker Switch (HORN/MAN)
SW-40	Lighted ON/OFF Rocker Switch (LCS653)

ONE YEAR LIMITED WARRANTY

The manufacturer warrants each new product against factory defects in material and workmanship for one year after the date of purchase. The owner will be responsible for returning to the Service Center any defective item(s) with the transportation costs prepaid. The manufacturer will, without charge, repair or replace *at its option*, products, or part(s), which its inspection determines to be defective. Repaired or replacement item(s) will be returned to the purchaser with transportation costs prepaid from the service point. A copy of the purchaser's receipt must be returned with the defective item(s) in order to qualify for the warranty coverage. Exclusions from this warranty include, but are not limited to, bulbs, strobe tubes, domes, and/or the finish. This warranty shall not apply to any light, which has been altered, such that in the manufacturer's judgment, the performance or reliability has been affected, or if any damage has resulted from abnormal use or service.

There are no warranties expressed or implied (including any warranty of merchantability or fitness), which extend this warranty period. **The loss of use of the product, loss of time, inconvenience, commercial loss or consequential damages, including costs of any labor, are not covered.** The manufacturer reserves the right to change the design of the product without assuming any obligation to modify any product previously manufactured.

This warranty gives you specific legal rights. You might also have additional rights that may vary from state to state. Some states do not allow limitations on how long an implied warranty lasts. Some states do not allow the exclusion or limitation of incidental or consequential damages. Therefore, the above limitation(s) or exclusion(s) may not apply to you.

If you have any questions concerning this or any other product, please contact our **Customer Service Department** at (585) 226-9787.

If a product must be returned for any reason, please contact our Customer Service Department to obtain a Returned Materials Authorization number (RMA #) before you ship the product back. Please write the RMA # clearly on the package near the mailing label.

NOTICE

Due to continuous product improvements, we must reserve the right to change any specifications and information, contained in this manual at any time without notice. Signal Vehicle Products and/or the manufacturer make no warranty of any kind with regard to this manual, including, but not limited to, the implied warranties of merchantability and fitness for a particular purpose. Signal Vehicle Products and/or the manufacturer shall not be liable for errors contained herein or for incidental or consequential damages in connection with the furnishing, performance, or use of this manual.